

CARDAFLEX®

** Torsional flexibility
 * Radial flexibility
 ** Axial flexibility
 ** Conical flexibility

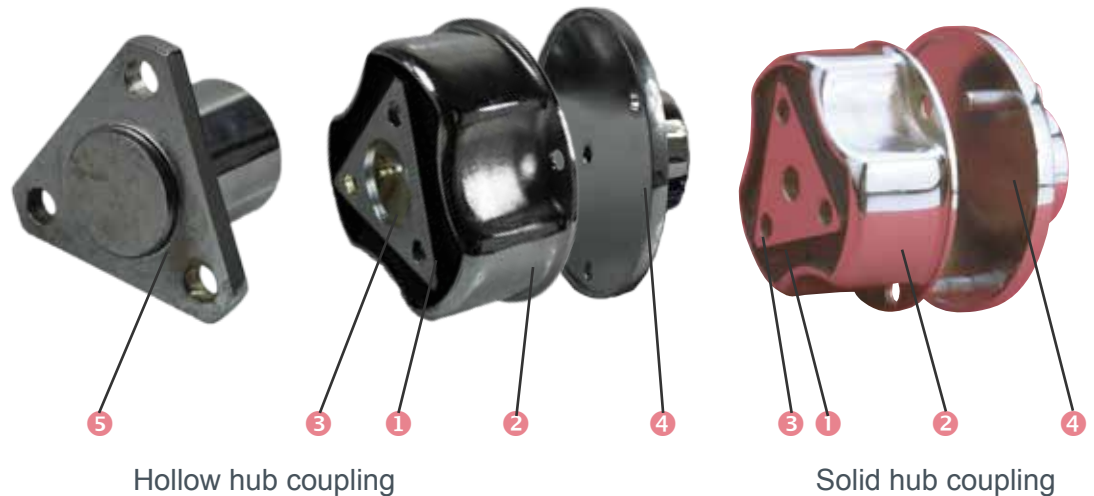

DESCRIPTION

There are two variations of the CARDAFLEX coupling : hollow hub and solid hub :

- Flexible element
 - ① Formed of solid natural rubber.
 - ② External steel surround, bonded to the rubber.
 - ③ Triangular hub: a hollow hub bonded to the rubber and attached to the flange ⑤, or a solid hub which accommodates a grooved or keyed shaft.
- Steel flanges
 - ④ round.
 - ⑤ triangular.

OPERATION

The CARDAFLEX coupling is designed with the following features :

- safe in use;
- fairly low conical stiffness;
- compact shape;
- Good performance at high speeds.

Advantages

- Especially in the case of the CARDAFLEX solid hub coupling, the space occupied by the unit is much reduced.
- The outer surround of the flexible element can be centred directly onto the flywheel of one of the machines to be coupled.

DIMENSIONS

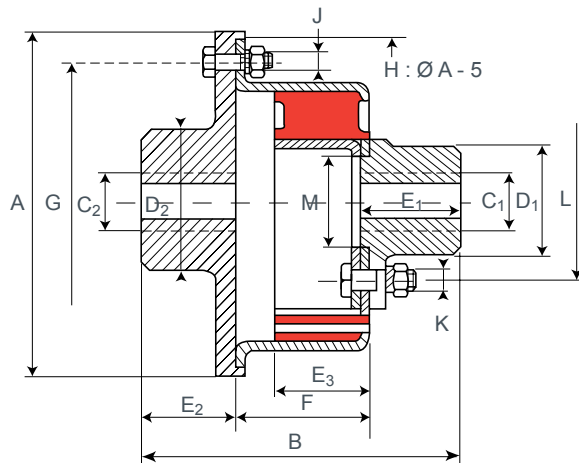

Hollow hub coupling

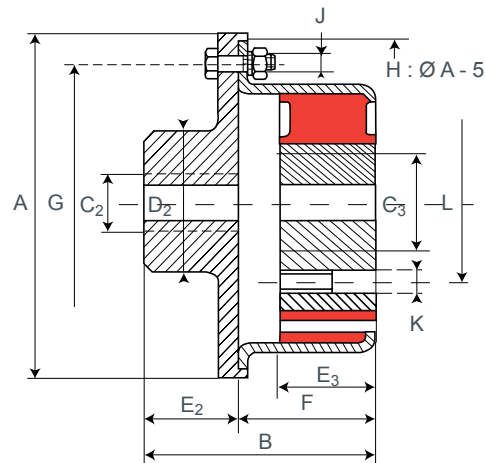

Solid hub coupling

HOLLOW HUB

Ref.	Nominal torque (N.m)	Max torque (N.m)	Max speed (rpm)	Hole size C ₁ (mm)		Hole size C ₂ (mm)		A (mm)	B (mm)	D ₁ (mm)	D ₂ (mm)	E ₁ (mm)	E ₂ (mm)	E ₃ (mm)	F (mm)	G (mm)	J (mm)	K (mm)	L (mm)	M (mm)	Weight (kg)
				min	max	min	max														
622310	50	100	6 500	7	19	7	28	105	100	34	45	33	30	28	40	86	6	8	52	30	1,6
622311	80	160	6 000	9	20	9	30	120	125	32	50	44	40	35	45	100	6	8	52	30	2,3
622312	120	240	5 500	9	25	9	36	130	140	40	55	49	45	35	50	108	8	10	64	36	2,8
622315	160	320	5 500	9	32	9	42	155	155	49	60	55	50	43	55	130	10	12	76	42	4,5
622320	520	1 040	4 500	11	42	11	56	205	203	67	80	71	65	57	73	175	12	16	100	56	10,7

1 N.m ≈ 0,1 mkg

Please see current price list for availability of items.

SOLID HUB

Ref.	Couple nominal TCN (N.m)	Couple maxi (N.m)	Max speed (rpm)	Hole size C ₂ (mm)		Hole size C ₃ (mm)		A (mm)	B (mm)	D ₂ (mm)	E ₂ (mm)	E ₃ (mm)	F (mm)	G (mm)	J (mm)	K (mm)	L (mm)	M (mm)	Weight (kg)
				mini	maxi	mini	maxi												
622401	30	60	7 000	7	24	10	21	85	60	40	28	26	32	68	6	7	42	42	0,4
622402	50	100	6 500	7	28	16	28	105	70	45	30	28	40	86	6	8	52	52	0,7
622403	80	160	6 000	9	30	17	28	120	85	50	40	35	45	100	6	8	52	52	1
622404	120	240	5 500	9	36	18	36	130	95	55	45	35	50	108	8	10	64	64	1,2
622405	160	320	5 500	9	42	22	42	155	105	60	50	43	55	130	12	12	76	76	2,3
622406	520	1 040	4 500	11	56	30	56	205	138	80	65	57	73	175	16	16	100	100	5

1 N.m ≈ 0,1 mkg

Please see current price list for availability of items.

The maximum torque is considered to be an infrequent start-up torque and is not periodic.

PARTS LIST

Coupling Reference	Flexible element		Flange		Triangular flange Reference	Qty
	Reference	Qty	Reference	Qty		
622310	622210	1	321631	1	321636	1
622311	622211	1	321641	1	321646	1
622312	622212	1	321651	1	321656	1
622315	622215	1	321661	1	321666	1
622320	622220	1	321671	1	321676	1
622325	622225	1	321681	1	321686	1

Coupling Reference	Flexible element		Flange	
	Reference	Qty	Reference	Qty
622401	622108	1	321621	1
622402	622110	1	321631	1
622403	622111	1	321641	1
622404	622112	1	321651	1
622405	622115	1	321661	1
622406	622120	1	321671	1
622407	622125	1	321681	1

OPERATING LIMITS

POWER RANGE

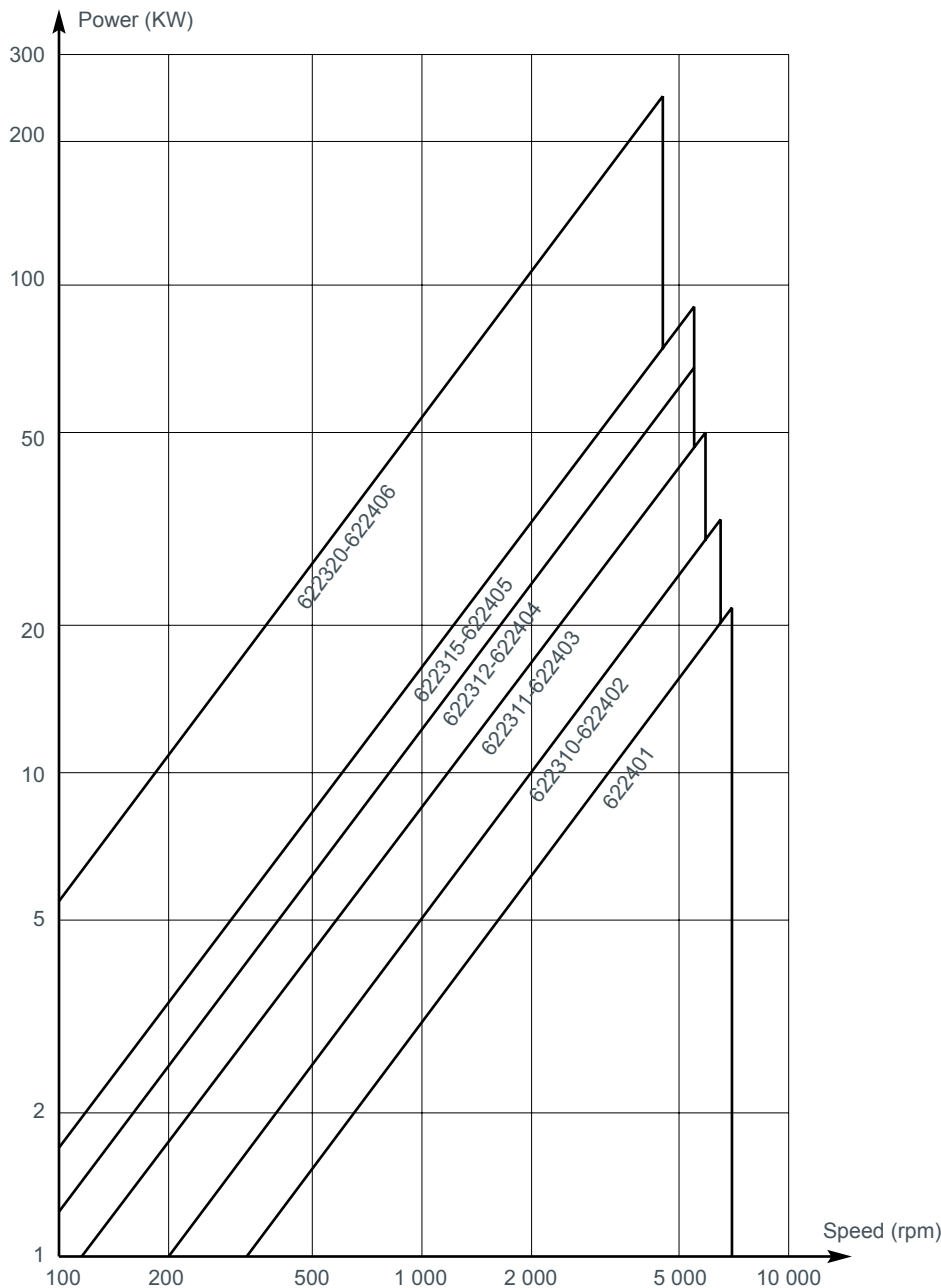

OPERATING CHARACTERISTICS

Nominal torque (N.m)	Vibrat. coupling (N.m)	Torsion under NT (degrees)	Stiffness			
			Axial (Dan/Mm)	Radial (Dan/Mm)	Torsional (M.kn/Rad.)	Conical (M.kn/Rad.)
30	15	6	30	100	0,286	0,114
50	25	7	16	65	0,400	0,114
80	40	5	30	90	0,860	0,23
120	60	8	25	80	0,860	0,23
160	80	5	32	90	1,72	0,46
520	260	7	40	150	4	1,14

1 N.m ≈ 0,1 mkg

ASSEMBLY

Method :

- mount the round flange onto the shaft of one machine.
- Mount :
 - the triangular flange onto the other shaft (hollow hub coupling);
 - the flexible element onto the other shaft (solid hub coupling).
- Attach the flexible element to the round flange.

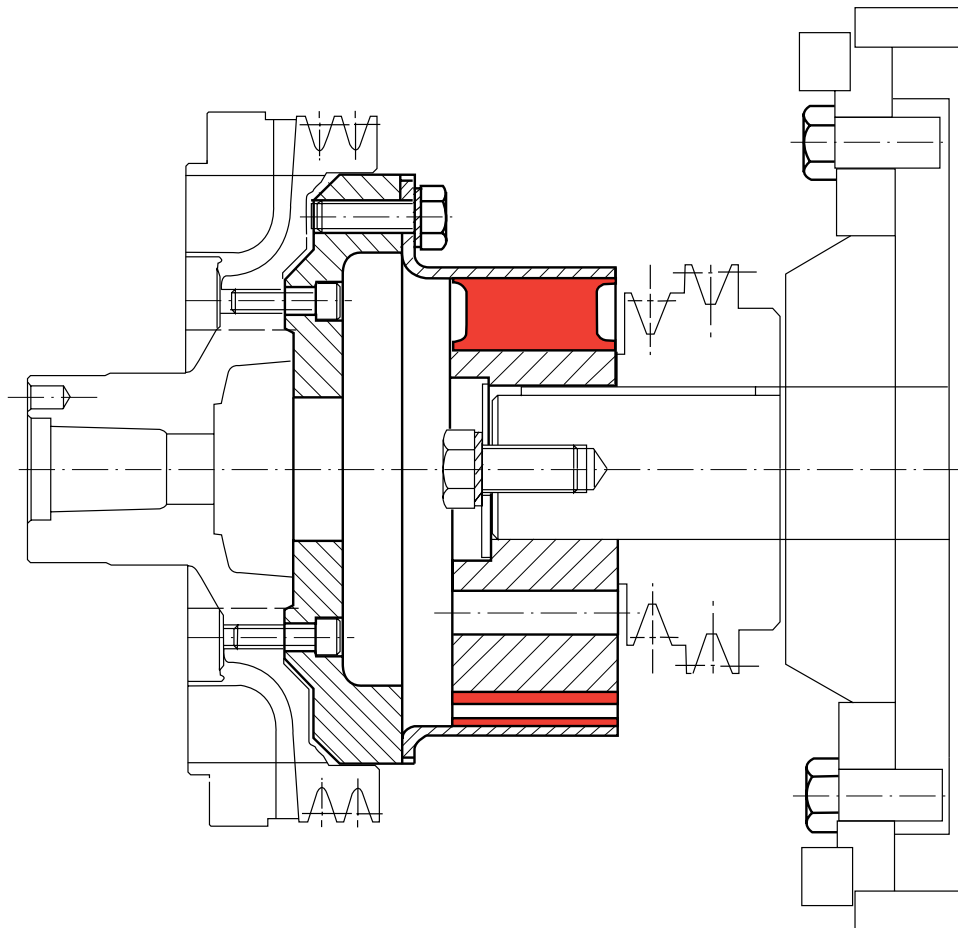

Example : internal combustion engine/hydraulic pump coupling : mounted on keyed shaft and on pulley.